

Investigations of Liquid Phase Aluminothermic Reduction of Ilmenite

Vitaly Babyuk, Bernd Friedrich, Vladyslav Sokolov

The constant increase of the demand for ferrotitanium can be covered only by reduction of titanium ores. The basic condition for realization of this option is improving the aluminothermic reduction (ATR) technologies that are already applied mostly for ilmenite. A non-traditional approach is presented, starting the ATR process by adding aluminium after complete smelting of ilmenite provides better kinetic conditions for production of ferrotitanium. Additionally this metal is cleaner with respect to gas impurities. Moreover it has the potential for easier process control in comparison with the usual ATR that starts in a completely solid charge. This situation stipulates for carrying out a fundamental investigation including thermochemical modeling, bench scale experiments connected with thermoanalytical measurements (DTA/TG) and pilot ATR trials. The received results contribute to improve-

ments of the ferrotitanium process. The ferroalloy produced in pilot experiments contains (wt.-%) Ti 18.8-48.5, Al 0.8-17.3, Si 0.65-2.6, Fe and admixtures bal. It is also very important that the content of dissolved oxygen is 0.8 wt.-% and of nitrogen 0.001 wt.-%. That is sufficiently lower than got by the other technologies without application of inert atmosphere or vacuum. The average yield ratio for Ti is 65 wt.-%. That is normal result even for the large scale industrial conditions. The developed approaches can be used for working out ATR technologies for other alloys including Ti base materials.

Keywords:

Ferrotitanium – Thermochemical modelling – Derivatography – Aluminothermic reduction (ATR)

Untersuchungen der aluminothermischen Reduktion von Ilmenit in flüssiger Phase

Die ständige Zunahme der Nachfrage nach Ferrotitan kann nur gedeckt werden durch die Reduktion von Titanerzen. Die grundlegende Bedingung dafür ist die Verbesserung der Technologien der aluminothermischen Reduktion (ATR), die bereits hauptsächlich für Ilmenit angewandt werden. Es wird eine untraditionelle Methode vorgestellt, wobei durch Zugabe von Aluminiumpulver am Anfang des ATR-Prozesses nach dem vollständigen Schmelzen des Ilmenits bessere kinetische Bedingungen für die Herstellung von Ferrotitan herrschen. Weiterhin ist dieses Metall reiner hinsichtlich der gasförmigen Verunreinigungen. Darüber hinaus bietet es die Möglichkeit zur leichteren Prozesskontrolle verglichen mit der herkömmlichen ATR, die mit einer Charge in vollständig festem Zustand beginnt. Diese Ausgangslage erfordert eine grundsätzliche Untersuchung einschließlich thermochemischer Modellierung, Bench-Scale-Experimenten, verbunden mit thermoanalytischen Messungen (DTA/TG), und ATR-Pilotversuchen. Die ge-

fundenen Ergebnisse tragen zu Verbesserungen des Ferrotitan-Prozesses bei. Die in Pilotversuchen erzeugte Ferrolegierung enthält (in Gew.-%) Ti 18.8-48.5, Al 0.8-17.3, Si 0.65-2.6, als Rest Fe und Beimengungen. Von großer Bedeutung ist auch, dass der Gehalt an gelöstem Sauerstoff 0,8 Gew.-% beträgt und der von Stickstoff 0,001 Gew.-%. Diese Gehalte liegen deutlich unter denen, die durch andere Verfahren ohne inerte Atmosphäre oder Vakuum erreicht werden. Das durchschnittliche Ausbringen von Ti beträgt 65 Gew.-%. Dieses Ergebnis ist normal, auch für industrielle Großanlagen. Die entwickelten Methoden können verwendet werden, um ATR-Verfahren für andere Legierungen einschließlich Titan-Grundstoffen zu erarbeiten.

Schlüsselwörter:

Ferrotitan – Thermochemische Modellierung – Derivatografie – Aluminothermische Reduktion (ATR)

Investigation de la réduction aluminothermique d'ilménite en phase liquide

Investigaciones sobre la reducción aluminotermia de ilmenita en fase líquida.

1 Introduction

One of the most attractive options for application of the ATR technologies is broadening of ferrotitanium production. The introduction of this ferroalloy into the molten steel provides sufficient improvements of the properties

for the final product. Since ferrotitanium is mostly used for alloying of specialty steels, the tolerant level of dissolved gases is very low. Currently it is achievable with application of the rather expensive and scarce titanium scrap in the initial charge. The amount of the available Ti-scrap significantly varies every year in accordance with status in indus-

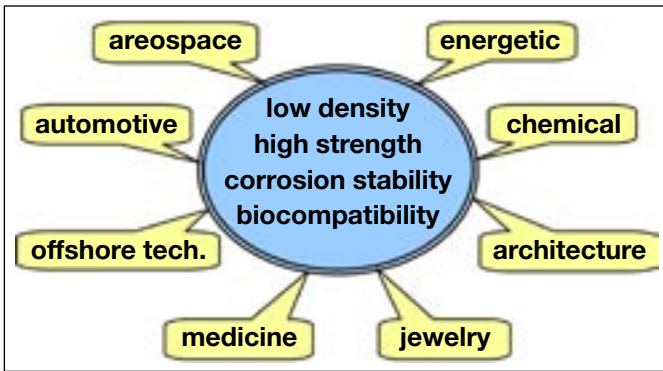

Fig. 1: Properties and applications of Ti-base materials

tries that consumes titanium alloys with specific properties (Figure 1). That fact limits capabilities for ferrotitanium production. The situation may become worse after anticipated improvement of the technologies for closed loop application of the titanium scrap. The constant increase in quality demands for ferrotitanium, given by the specialty steel metallurgy as well as the instability of the titanium scrap generation provokes fluctuations of its prices. A stabilization of the market may be reached if a stable alternative source of low cost titanium is provided, e.g. direct from ores. However the ATR grades of ferrotitanium currently produced are significantly admixed by detrimental gases and non-metallic inclusions. Thus the development of a cleaner ferroalloy process by ATR is an urgent task.

A new approach for the ATR process for ferrotitanium has been presented by SOKOLOV et al. [1, 2]. It is based on pouring of liquid ilmenite into the reactor before reduction starts. It allows interaction between reacting phases more intensive. A perfect phase separation takes place at the end of the process; the top slag prevents the melt from picking up undesired gases. The produced alloy has virtually the same purity as the corresponding vacuum melted alloy. No booster is needed for arranging self-consistency of ATR, as energy is already incorporated in the liquid melt. As the oxide phase essentially gets free of foreign gases during its smelting operation, this prevents explosion especially at the most dangerous starting phase. So the safety of the ATR process is significantly improved. A saving of aluminium is obtained at the same time, as less metal has to be oxidized

just that reacts for heating of the melt. Moreover a higher ratio between Ti and Al can be received. Since the temperature of the liquid phase can be varied just before the ATR starts an additional improvement of the process control occurs. In order to further optimize this process new fundamental knowledge about the ATR of ilmenite is necessary.

2 Thermochemical modelling

The thermochemical analyses generally are grounded on the basic equation for all metallothermic reactions shown by DUBROVIN [3]:



The real process is characterized by diversity of elements to be reduced (Me') and even sometimes reducing agents (Me''). There may be plenty of fluxing components and other admixtures that influence the process. Therefore a variety of reactions with formation of solutions and compounds in the metallic and slag phases should run simultaneously. The equilibrium of Reaction (1), reduction of $Me'X$, is on the products side, if the Gibbs energy ΔG_1 is < 0 . This condition takes place if $\Delta G_{(Me''X)} < \Delta G_{(Me'X)}$. However the activity coefficients of reacting and forming substances have to be taken into account in the process simulation. This makes the calculation complex.

The FactSage software worked out and presented by BALE et al. [4] was used for the purpose of facilitating the theoretical modelling of the equilibrium for the ATR process. The reliability of this tool in modeling ATR of the titanium oxide had been proved by FRIEDRICH et al. [5]. The module Equilib was applied for simulation of ATR of ilmenite for ferrotitanium production. The proper choice of the data bases for compounds and solutions is one of the basic conditions for getting acceptable results. The selection of insufficient and non-reliable bases causes incorrect process simulation. And usage of all available data bases leads to overloading by the received simulation results.

The calculated components content in the liquid metal and slag depend on the amount of Al added as shown in Figure 2. The theoretically achievable composition range of ferrotitanium meets the Russian industrial ATR grade FeTi35S8 that may contain wt.-% Ti 28 to 40 and Al up to

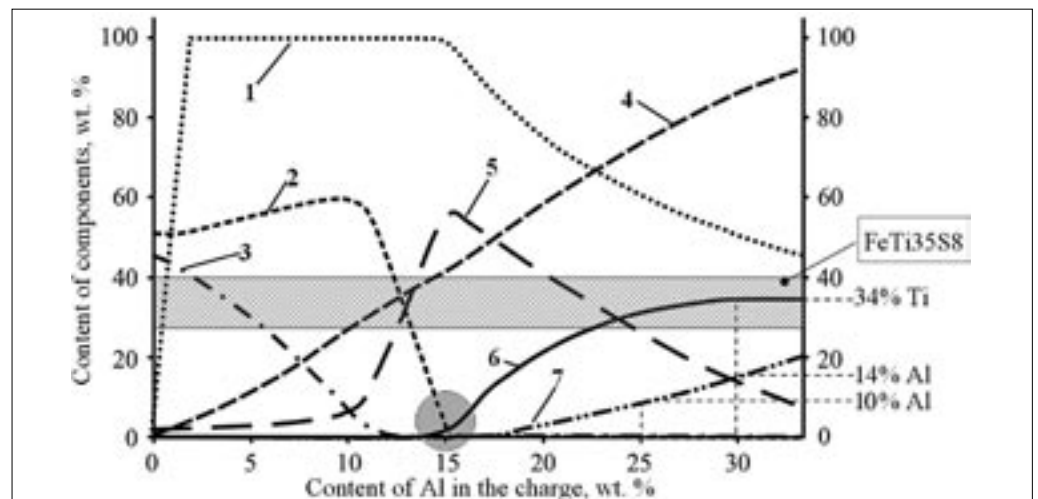

Fig. 2: The equilibrium content of phases generated after ATR of ilmenite with content of Al in initial charge
 1 = Fe in liquid metal, 2 = TiO_2 in slag, 3 = FeO in slag, 4 = Al_2O_3 in slag, 5 = Ti_2O_3 in slag, 6 = Ti in liquid metal, 7 = Al in liquid metal

14 tolerating the Russian Standard [6]. It usually is produced only from ilmenite ores. It can be seen that titanium reduction starts immediately after complete reduction of iron oxides if the content of Al in the charge is higher than 15 wt.-% This area is circled. The extraction ratio of Ti increases with further growth of the Al content in the charge. However if the content of Al in the charge exceeds 30 wt.-% a ratio between Ti and Al significantly drops and the process becomes ineffective due to significant unjustified consumption of Al and correspondent its higher content in the final product. It has been found that for receiving an acceptable content of Al less than 10 wt.-% it is necessary to add no more than 25 wt.-% Al into the charge. The extraction ratio of Ti at this condition can be expected to 63 %, which meets industrial experiences of current ATR technologies reported by PAZDNIKOV et al. [7].

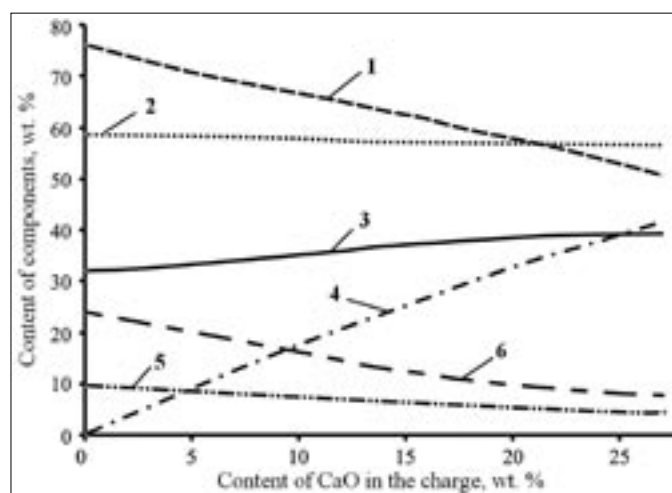
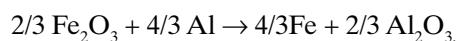
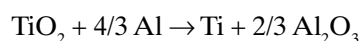

Fig. 3: Influence of CaO on the content of components generated during ATR of ilmenite - 20 wt.-% Al in the charge
1 = Al_2O_3 in slag, 2 = Fe in liquid metal, 3 = Ti in liquid metal, 4 = CaO in slag, 5 = Al in liquid metal, 6 = Ti_2O_3 in slag

The influence of CaO on the Al/Ti-ratio in the product at the traditional 20 wt.-% Al level in the charge is shown in Figure 3. An increase of CaO up to 13 wt.-% causes the desired increase of Ti and amounts 5 wt.-% in the product, correspondingly a decrease of Al is reached of 3.5 wt.-%. On the other hand the addition of CaO into the charge kinetically facilitates the interphase reactions. The major of them are:



As shown by LYAKISHEV et al. [8] several additions to an ATR charge sufficiently facilitate the reaction. Namely, some chlorides, fluorides as well as cryolite decrease the temperature of the ATR start to 100 to 300 °C. The effects and mechanisms of the salt addition on ATR chromium oxide has been reported by DUBROVIN et al. [9]. They assist the reaction by dissolving and removing aluminium oxide from the reaction zone. Our calculations with FactSage proved the thermochemical effect of several additions on the equilibrium temperature (Figure 4). The efficiency of additions is decreasing in the following order: AlF_3 , cryolite, salts of the rare earth metals and salts of the alkaline metals.

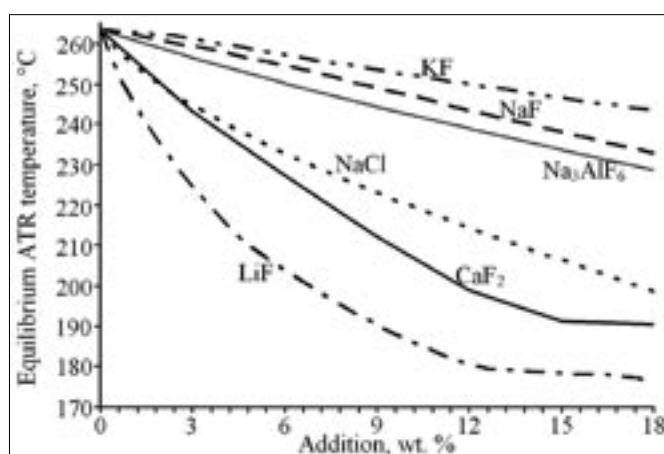

Fig. 4: Effect of additions on the equilibrium temperature of ATR of ilmenite - 20 wt.-% Al in the charge

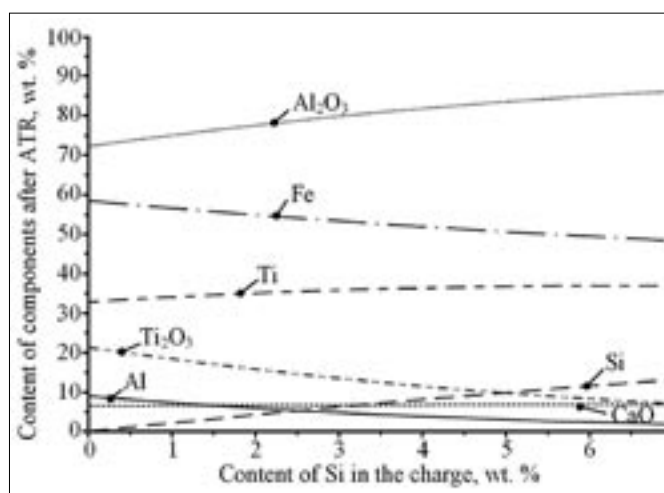

Fig. 5: Influence of Si in the charge on the ATR of ilmenite - 20 wt.-% Al in the charge

Final calculations refer to the impact of silicon in the process. Figure 5 demonstrates how the ATR process can be facilitated with increase of the silicon content in the melt.

3 Thermoanalytical investigations (DTA/TG)

As stated by SAMSONOV et al. [10] the ATR reactions are of two stages nature. The stages are very different. The first one is a low temperature starting period with stable regime of a slow process. However it provides conditions for proceeding of the basic reactions. The second stage is a none-stable self consistently accelerating process finished by ignition of the entire reaction mixture. The DTA method is suitable for investigation of the low temperature period. The derived mechanisms should be extrapolated to the elevated temperature interval. The reduction of oxides by Al starts at the solid state in the zones of direct contact of ilmenite particles with Al ones at 400 to 600 °C. The reduction reaction at the low temperatures as reported by LYAKISHEV [8] runs mostly as the result of the diffusion of Al to the contacting interface of the reagents. A following temperature increase leads to capillary filtration of generating liquid Al under the wetting force into the solid part of the charge and the reaction accelerates significantly.

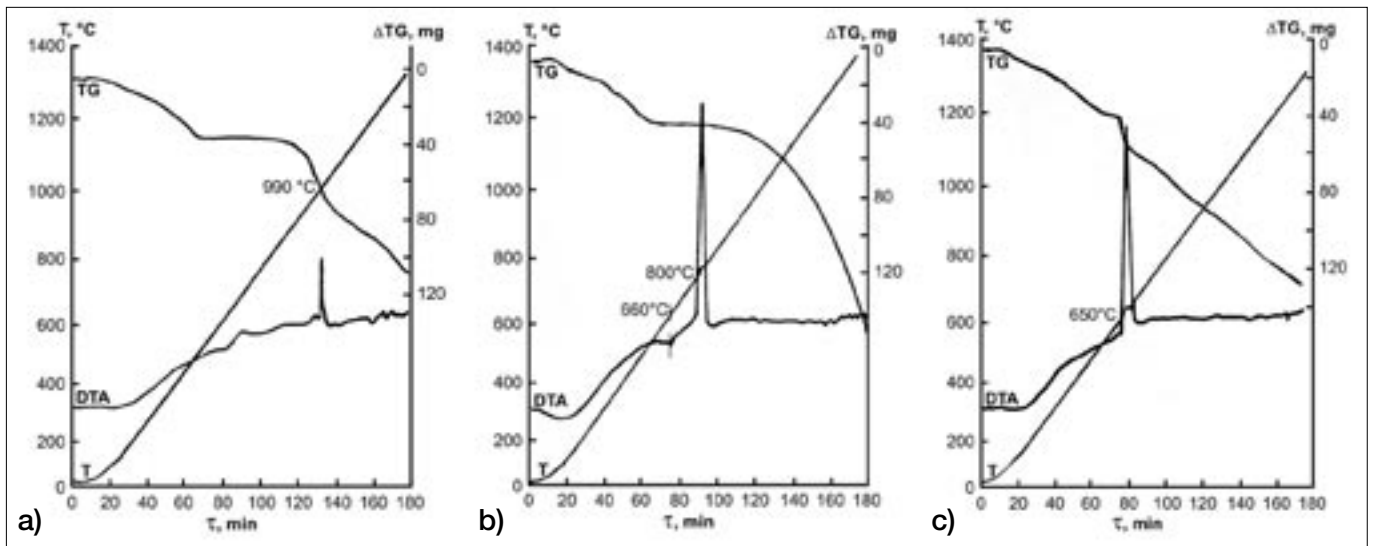

Fig. 6: Thermoanalysis (DTA/TG) of reaction of ilmenite with 25 wt.-% Al with 5 wt.-% additions: a) = Na_3AlF_6 ; b) = NaF ; c) = NaCl

For orientation the ATR of ilmenite was carried out in a laboratory electric resistance furnace adding 20 to 25 wt.-% Al. A CO-based low reductive atmosphere in the furnace was served by oxidation of its heating carbon tube. The temperature of beginning exothermic reaction in the mixture was determined while rising the furnace temperature with a rate of 30 to 40 °C/min. The influence of the mixture weight was investigated using 0.5, 1.2, 2.5 and 7 cm³ crucibles. Facilitating additions were CaF_2 , NaF , NaCl and Na_3AlF_6 . The composition (wt.-%) of ilmenite was TiO_2 62.85, MgO 1.24, Al_2O_3 4.08, SiO_2 2.25, Cr_2O_3 1.72, MnO 0.71, CuO 0.35. The experiments showed that during exothermic reaction the temperature of the mixture raised up to 1200 to 1300 °C. The temperature of the ATR start varied between 200 to 600 °C dependently from the type of facilitating additions. Only the smallest crucible did not lead to reliable results.

More precisely the reaction start temperature was determined by differential thermal analyses (DTA) using ilmenite base mixtures. For investigation of the ATR process and especially of the low temperature stage of its oxides reduction the derivatographic method was applied. The ATR reactions were investigated under air or flowing argon (80 to 120 cm³/min.) atmosphere. The DTA of the prepared mixtures were conducted with simultaneous measurement of the weight change (TG). The DTA reference was annealed Al_2O_3 that did not have phase transformation during heating. It was placed into an identical crucible of that for the sample. The thermocouples were put into pockets of the both crucibles and connected by the differential scheme.

Measurements of pure ilmenite without Al addition showed an endothermic effect at 100 to 200 °C. It was connected with evaporation of absorbed moisture. The correspondent weight loss of the sample was 0.5 to 0.6 %. The endothermic extraction of coordinated bounded OH-groups occurred at 900 to 1100 °C. The weight loss of ilmenite was 0.3 to 0.5 % at that time. No further effects could be detected until 1300 °C. In the following heating of various reaction mixtures with different fluxing and aluminium additions was carried out from 20 °C to 1500 °C.

Table 1: Influence of 5 wt.-% fluxing additives on the starting temperature of ATR in a mixture of ilmenite with 25 wt.-% Al

Additive	NaCl	NaF	CaF_2	Na_3AlF_6	None
ATR starting temperature [°C]	650	800	950	990	1060

The smelting of pure ilmenite is characterized by periodic boiling of the molten bath, if the provided power is being slightly decreased for a short time a solid crust is being generated followed by solidification of the melt. During the experiments it has been found that Al_2O_3 negatively influences the ATR process. The influence of some of the additives on the thermal effects are shown in Figure 6 and summarized in Table 1. The Al- and additive concentration in the mixture with ilmenite was 25 wt.-% respectively 5 wt.-%.

The cryolite content in the mixture lowers the ATR starting temperature from 1060 °C down to 990 °C (Figure 6a). Besides it was found out that its increase from 2 to 5 wt.-% raised the peak intensity at the DTA curve about 2.5 times. Figure 6b shows that the basic starting temperature is reduced to 800 °C. The most effective addition is 5 wt.-% NaCl (Figure 6c). It lowers the ATR starting temperature down to 650 °C. It corresponds with generation of the melting point of Al.

The final reaction product after the thermoanalytical investigation was in a form of calcined powder. Its phase composition was analyzed by XRD. It has been found that during the starting period the following phases are formed: Fe, Ti, Al_3Ti , $\text{Ti}_9\text{Al}_{23}$, TiO , Ti_2O_3 , FeO. These are also known from industrial ferrotitanium production.

4 Pilot ATR experiments

For generation of liquid titanium slag a modified electroslag remelting furnace (ESR) was applied. The melting mechanism of traditional ESR is based on utilization of energy generated by the electric current passing a liquid flux. This principle has been transferred by MEDOVAR et al. [11]

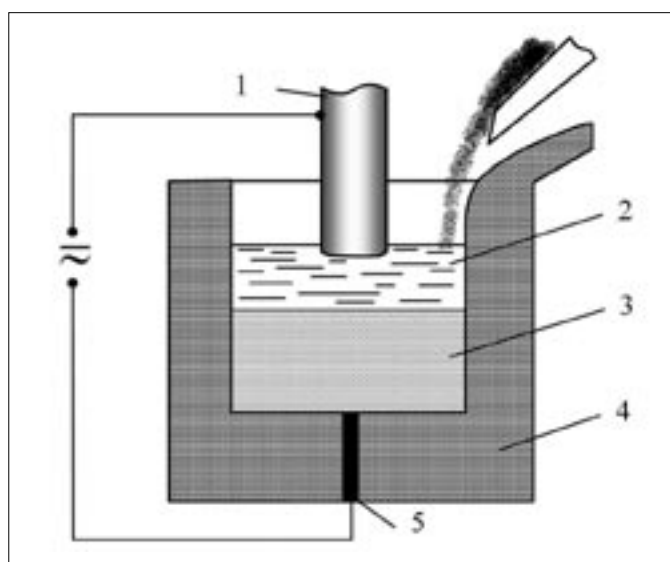

Fig. 7: ESCR melting of fine materials in a electroslag crucible furnace equipped with a non consumable graphite electrode
 1 = non consumable graphite electrode; 2 = slag/flux; 3 = molten metal; 4 = crucible, 5 = bottom electrode



Fig. 8: Stationary a) and portable b) versions of ESCR furnaces

to electroslag crucible remelting (ESCR). The electric current runs through the upper electrode towards the bottom one buried in the crucible lining. Also electric arc regimes can be arranged in definite circumstances. Several unique features have been found out during usage of the process. Among them was an option of smelting of the fine materials with application of the conditionally non-consumable graphite electrode (Figure 7).

Since the conditions of conventional ferroalloy smelting can be reached in ESCR furnace it was used for the present investigations, either in a portable or in a stationary version (Figure 8). The portable one is rather simple to apply anywhere since there is no need for a foundation or for a water-cooling system.

The five indicative experiments for finding suitable conditions for the ATR process are demonstrated. The feedstock (Ti-/Fe-oxide, solid CaO) was carefully weighed and manually mixed. Experimental procedure included a starting phase where an arc between the upper and the bottom electrodes was generated. After that charging of the mixture in portions into the furnace was carried out. At last tapping of a melt into a reactor with simultaneous introduction of solid Al was made. The application of comparatively large electrodes with \varnothing 150 mm was preferable due to the specific properties of the molten titanium-oxides. Addition of lime to the charge provides, as discussed above, an option to stabilize the melting process by decreasing the liquidus temperature. The amount of CaO should vary between 5 and 10 wt.-% of the charge. Suitable electric parameters have been found to be $U = 30$ to 40 V, $I = 2.0$ to 2.5 kA. The electrode has to be submerged into the molten oxide melt on 20 to 40 mm depth.

The results of the melts are shown in Table 2. In addition it has been found out that the content of dissolved oxygen is 0.8 wt.-% and of nitrogen 0.001 wt.-% That is much lower than received by melting of scraps in an open induction fur-

##	Ti	Al	Si	Cr	Mn	Cu	Input/output materials [kg]
Melt in the portable furnace							
1	30.5	4.5	1.4	1.0	1.0	-	Ilmenite – 11.4 CaO – 0.6 Al – 3 Ferrotitanium – 2.4
Melt in the stationary furnace							
2	48.5	13.3	2.4	0.86	0.76	-	Ilmenite – 39.9 CaO – 2.1 Al – 18 Ferrotitanium – 22
Melt in the stationary furnace							
3	48.5	13.8	2.6	0.95	0.64	-	Ilmenite – 114 CaO – 6 Al – 40 Ferrotitanium – 37
Melt of mixture of rutile and iron oxides with different content of introduced Al in the portable furnace							
4	18.78	0.8	1.09	0.8	1.42	-	Rutile – 4 FeO – 1 CaO – 0.35 Al – 2.15 Ferrotitanium – 3.37
5	39.9	17.3	1.03	0.48	1.39	-	Rutile – 3 FeO – 2 CaO – 0.5 Al – 1.5 Ferrotitanium – 1.5

Table 2:
 Chemical composition and weight of the produced ferrotitanium, weight of charged components

nance. The corresponding figures based on the experience of a Ukrainian ferrotitanium producer (Complex Alloys Company) [12] are 2 wt.-% and 0.12 wt.-% respectively.

The highest extraction ratio is for Ti 65 % that meets the theoretical expectations calculated for equilibrium conditions. The content of Al varied in the broad limits 1 to 14 wt.-% Basically it depends on the content of Al in the initial charge. The applied Ti oxidized materials contained sufficient amount of Si in the charge. Most part of Si got ferrotitanium after ATR. It was 1.4 to 2.6 wt.-% Si in the product after usage of ilmenite in the charge. Comparing ilmenite and rutile (wt.-% $\text{TiO}_2 \geq 95.6$, $\text{ZrO}_2 < 0.5$, $\text{Fe}_2\text{O}_3 < 1.71$; $\text{Al}_2\text{O}_3 < 0.31$; $\text{SiO}_2 < 1.35$; $\text{P}_2\text{O}_5 < 0.07$; $\text{SO}_3 < 0.05$; $\text{H}_2\text{O} < 0.06$) feedstocks shows mostly the same efficiency for Ti extraction. However, ilmenite substitution by rutile, which is poorer in Si, brought the content of Si down to 0.65 to 1.1 wt.-%.

Unfortunately it was found that the eutectic ferrotitanium (70 wt.-% Ti; 30 wt.-% Fe) can not be produced in a sufficient purity direct from a single batch (ATR charge). But the metal produced meets the Russian standard [6], wt.-%: Ti 28 to 40, Si max. 8, Al max. 14. The content of Si in our product is higher than in the ferrotitanium produced from Ti scrap. Similar results were received after replacement of ilmenite by a mixture of rutile and iron oxides in equivalent proportions. Nevertheless the presence of Si in the feedstock has some positive effect on Ti-extraction yield as already presented in chapter 2 (thermochemical calculations).

5 Summary and outlook

Improving the ATR technologies for production of ferrotitanium from ilmenite is needed in order to ensure the future ferrotitanium supply. It is especially important to produce a higher quality product with respect to dissolved detrimental gases and non-metallic inclusions. The innovative approach for starting ATR after complete smelting of ilmenite without application of any ignition mixture provides several evident advantages. They include more safety of the technology, better kinetic potential for the reactions followed by separation of generated phases and tighter control of the ATR process parameters. The latter anticipates deep fundamental investigation of ATR including thermochemical modelling, bench scale study of the reactions and pilot trials. Theoretical investigations were made with application of the FactSage software. The major results from this work are the equilibrium components content in the liquid metal and slag depend on the charge composition as well as the equilibrium ATR temperatures. Some of these like achievable ferrotitanium composition and extraction rates as well as the positive influence of lime and silicon in the charge were proved already by current industrial experience. Other theoretical results including optimal composition of the initial ATR charge and influence of additions on the reaction were used for designing own experiments.

We proved sufficient efficiency of the proposed ATR in bench scale tests although the available thermoanalytical/

derivatographic equipment provides temperatures noticeably lower than occurring in the real ATR processes. As main result of the derivatographic investigations we determined the order of intensification by adding the facilitating additions Na_3AlF_6 ; CaF_2 ; NaF ; NaCl . They are listed in the order of increase of their influence. Portable and stationary electroslag crucible (ESCR) furnaces were used for generation of the ilmenite and rutile base melts that reacted in the following with Al in a separate reactor. The produced ferrotitanium met the specifications of the common grade of ferrotitanium. Moreover our material showed a significantly lower content of dissolved oxygen and nitrogen due to protection of the melt from interaction with air by the generated slag. Also the perfect phase separation was helpful for minimization the content of detrimental non-metallic inclusions. The produced extraction rate of Ti was comparable to the expected figure calculated for the equilibrium case. It was also found out that the content of Si in the final product from rutile is somewhat lower than using ilmenite.

The developed process methodology and parameters are basis for investigation of other ATR processes for titanium. The last five to ten years are characterized by recommencement of correspondent investigations. Their main goal is reduction of the production costs by increasing the efficiency of the ATR process, e.g. for γ -TiAl. As an example MAEDA et al. [13] found out by laboratory trials that the rate of the reduction of titanium oxides by Al was rather fast at 1973 K. The content of oxygen in the produced intermetallic composition was 1.5 wt.-%. Recently FRIEDRICH et al. [14] carried out series of theoretical and experimental investigations on ATR production of the γ -TiAl alloy by so called the IME TiAl-process. The ATR approach was validated experimentally. At the same time the feasibility of ESR for deoxidation of the produced master alloy with application of CaF_2 -Ca fluxes have been proved. It was calculated that in definite conditions the oxygen content can be reduced from 1.4 wt.-% to $1.5 \cdot 10^{-4}$ wt.-%. As a matter of fact this figure is even lower than the actual content of oxygen in the commercial VAR γ -TiAl master alloy that figures $6.0 \cdot 10^{-4}$ wt.-%. The received effects of facilitating additions that reduce the starting temperature should be very helpful for ATR of titanium oxides. It is sufficiently higher than for ATR of ilmenite.

Acknowledgements

The authors would like to thank INTAS for the financial support given by the YS Fellowship grant N° 04-83-2798 to the development of this research. The assistance and support of Yuvenaly Skok in the thermoanalytical investigations, Jan-Christoph Stoephasius in the FactSage calculations and Ewgen Zhydkov in the pilot ATR trials is gratefully noted.

Literature

- [1] SOKOLOV, V.M. et al. (1999): Study of the possibility of ferrotitanium production from ilmenite concentrate in ESR furnace. – Titanium '99 – Science and Technology, Proceedings of the Ninth World

- Conference on Titanium Central Research Institute of Structural Materials (CRISM) "Prometey", Saint-Petersburg, Russia: Vol. 3, pp. 1486-1491.
- [2] SOKOLOV, V.M. et al. (to be published): Aluminothermic studies of a liquid partial reduced ilmenite. – Environmental Science & Engineering magazine.
- [3] DUBROVIN, A.S. (2002): Metallurgy of special-property alloys: 253 p.; Chelyabinsk (YuUrGU).
- [4] BALE, C.W. et al. (2002): FactSage thermochemical software and databases. – Calphad, **26**: 189-228.
- [5] FRIEDRICH, B., HAMMERSCHMIDT, J. & STOEPHASIUS, J.-C. (2003): Aluminothermische Reduktion von Titanoxid. – ERZMETALL, **56**: 82.
- [6] Ferrotitanium: Technical Requirements and Terms(1992). GOST 4761-91, Moscow (State Publishing House of Standards).
- [7] PAZDNIKOV, I.P. et al. (2005): Into problems on optimization of technology for production of high quality ferrotitanium. – Ref. of International Conference Ti-2005 in NIS, Ukraine, Kiev: 169-171.
- [8] LYAKISHEV, N.P. et al. (1978): Aluminothermy: 424 p.; Moscow (Metallurgia).
- [9] DUBROVIN, A.S. et al. (1968): Influence of salt additions on velocity of metalothermic processes. – Izv. AN SSSR. Metal, **5**: 79-88.
- [10] SAMSONOV, G.V. & PODERGIN, V.A. (1971): Metalothermic processes in chemistry and metallurgy: 5-25.
- [11] MEDOVAR, B.I. et al. (1988): Electroslag crucible melt and pouring metal: 216 p.; Kiev (Naukova Dumka).
- [12] Private communication with P.V. Sebstyanovich, President of Complex Alloys Company from Ukraine at the Conference of Interstate Association "Titan", Kiev 22 May 2004.
- [13] MAEDA, M. et al. (1993): Aluminothermic Reduction of Titanium Oxide. – Material Transaction, JIM, **34**, 7: 599-603.
- [14] FRIEDRICH, B. & STOEPHASIUS, J.-C. (2005): Production of γ -TiAl-ingots by Aluminothermic reduction of TiO_2 and refining by ESR. – Proceedings of European Metallurgical Conference 2005, Vol. 4, pp. 1429-1444.

Eng. Vitaly Babyuk
Physico-Technological Institute of Metals and Alloys of NASU
34/1 Vernadsky Avenue
Kiev-142, 03680
Ukraine
e-mail: vdbptima@mail.ru

Prof. Dr.-Ing. Bernd Friedrich
IME Metallurgical Process Technology and Metal Recycling
RWTH Aachen
Intzestr. 3
52056 Aachen
e-mail: bfriedrich@metallurgie.rwth-aachen.de

Dr. Vladyslav Sokolov
Gas Institute of NASU,
39, Dehtiarivska St.
03113 Kiev
Ukraine
e-mail: vlads@visti.com